

FEBRUARY 1, 1968

FORD

MUSTANG 64-66

**FRONT BUMPER**

R&R Bumper Assy. ★1.0  
O/H Incl. R&R ★1.2  
Deflector Time is w/Bumper Rem.

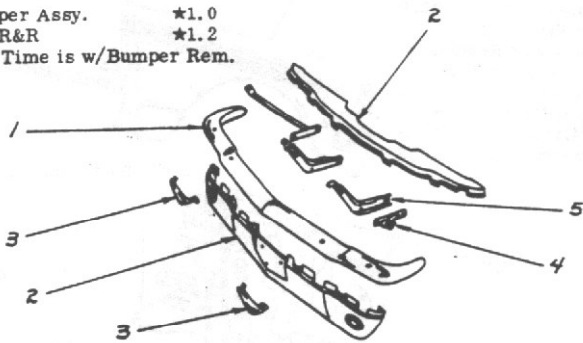

1. Bar, Face		C5ZZ 17757A	1.2	33.65
2. Deflector, Stone, Upper		C5ZZ 17779A	★★.7	9.70
	Lower	C5ZZ 17A939A	★★.6	9.70
		(#Both ★.8)		
3. Guard	R/H	C5ZZ 17996C	.3	5.50
	L/H	C5ZZ 17997B	.3	5.50
4. Arm, Outer		C5ZZ 17A869-70A		.55
	To Fender	C5ZZ 17A975-6A		2.15
	To Inner Arm	C5ZZ 17766-7A		3.15
5. Arm, Inner		C5ZZ 17B794A		.75
	To Bumper Guard			

**GRILLE**

R&I Grille Assy.  
Type w/Fog Lamps .6  
Type w/o Fog Lamps .4  
O/H Grille Incl. R&R  
Type w/Fog Lamps ★1.2  
Type w/o Fog Lamps ★1.0

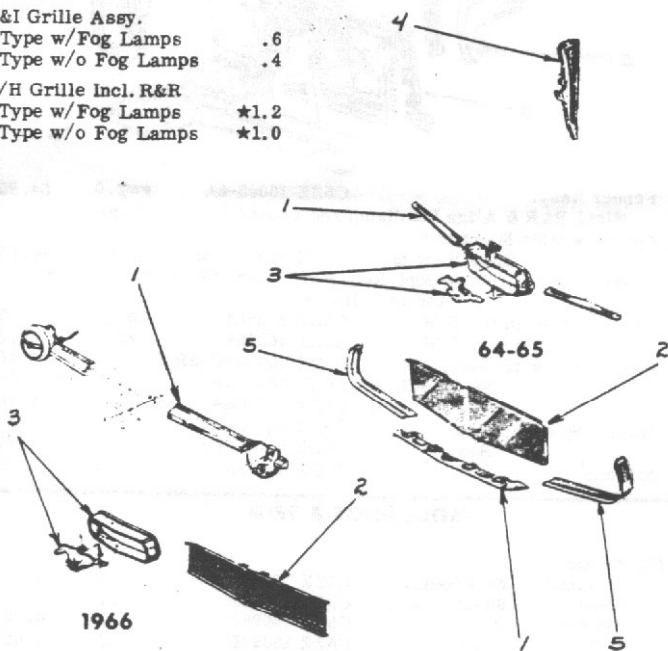

1. Bar, Grille Face				
	1965 Lower	C5ZZ 8390F	★.5	9.30
	Center, Exc.	C5ZZ 8390B-C	★.2	5.80
	w/Fog Lamps	C5ZZ 8390D-E	★.2	5.80
	1966 Lower	C5ZZ 8390F	★.5	9.30
	Center w/Fog Lamps.	C6ZZ 8390A-B	★.2	6.20
2. Screen, Grille				
	1965 w/o Fog Lamps	C5ZZ 8200C	.4	14.50
	w/Fog Lamps	C5ZZ 8200D	.4	14.50
	1966	C6ZZ 8200A	#	17.15
		(#.4 exc. G.T. .6)		
3. Ornament				
	1965	C5ZZ 8213A	★.3	14.80
	1966 w/o Fog Lamps	C6ZZ 8213A	★.3	12.20
	w/Fog Lamps	C6ZZ 8213B	★.5	14.80
4. Brace, Hood Latch		C5ZZ 16747A	★.3	1.75
5. Moulding Assembly				
	1965-66	C5ZZ 8242-3A	★★.5	4.35
	1966 Center Cover	C6ZZ 8221A		.75
		(#Both ★.6)		

**COOLING**

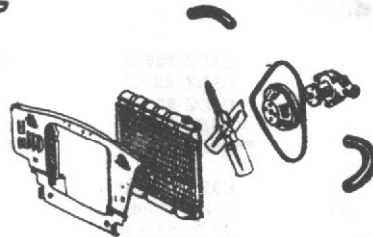

Radiator				
	1965 6 Cyl.	C5ZZ 8005C	#.7	50.60
	V8	C3DZ 8005K	#.7	50.60
	1966 6 Cyl.	C5ZZ 8005C	#.7	50.60
	V8, exc.	C3DZ 8005K	.7	50.60
	w/A.C.	C6ZZ 8005B	.9	55.55
		(#w/A.C. .9)		

Support, Radiator C5ZZ 16138A #★3.5 11.95  
(#Time is w/Bumper, Grille, Stone Deflector, Headlamps and One Fender Removed.)

Fan Blade				
	1965-66 6 Cyl. 170	C2UZ 8600A	#.4	4.00
	200, exc.	C2DZ 8600D	#.4	4.00
	w/A.C.	C5ZZ 8600B	#.4	11.60
	1965 V8, exc.	C2OA 8600B	#.4	4.30
	Special	C3OZ 8600C	#.4	11.95
	w/A.C., Gen.	C3OZ 8600D	#.4	11.60
	w/A.C., Alt.	C4OZ *600C	#.4	11.60
	w/A.C., Dealer	C3DZ 8600E	#.4	11.60
	1966 V8 Special	C3OZ 8600C	#.4	11.95
	Standard	*C5AZ 8600A	#.6	14.40
	w/A.C.	**C6OZ 8600A	#.4	4.30
		*C4OZ 8600D	#.6	11.60
		**C4OZ 8600C	#.4	11.60
		(#R&R w/Radiator Removed .2)		

Fan Belt, Std. Cooling				
	1965 6 Cyl.	C3DZ 8620B	#	1.60
	V8	C2OZ 8620L	#	2.70
	1966 6 Cyl.	*C6OZ 8620E	#	3.00
		**C3UZ 8620A	#	2.40
	V8, exc.	C4TZ 8620K	#	2.55
	Special	**C5OZ 8620A	#	2.35
		(#One Belt .2, Two Belts .3, Three Belts .4)		

Water Pump				
	1965 6 Cyl.	C6DZ 8501A	#1.0	14.15
	V8 w/Gen.	C5AZ 8501K	#1.0	16.00
	w/Alt.			
	Before Chg.#8	C5AZ 8501K	#1.0	16.00
	From Chg.#8	C5AZ 8501L	#1.0	18.45
	Spec. w/Gen.	C3OZ 8501B	#1.0	15.40
	Spec. w/Alt.			
	Before Chg.#8	C5OZ 8501A	#1.0	16.00
	From Chg.#8	C5OZ 8501B Disc.	#1.0	15.40

	1966 6 Cyl.	*C6DZ 8501A	#1.2	14.15
		**C6DZ 8501A	#1.0	14.15
	V8, exc.	*C5AZ 8501L	#1.2	18.45
		**C5AZ 8501E	#1.0	18.45
	Special	C5OZ 8501B Disc.	#1.0	15.40
		(#Add for A.C. - 6 Cyl. .2, 8 Cyl. .5)		

Pulley, Water Pump				
	1965 6 Cyl. 170 Std.	C0DE 8509A	#.5	2.00
	w/A.C.	C4DZ 8509B	#.5	6.45
	w/P.S.	C4DZ 8509A	#.5	2.75
	200 Std.	C3OZ 8509B	#.5	2.00
	w/A.C.	C5DZ 8509A	#.5	3.75
	w/P.S.	C5DZ 8509K	#.5	2.40
	V8 w/Gen., exc.	C2OZ 8509A	#.5	2.00
	w/A.C.	C2OZ 8509B	#.5	13.60
	w/Alt., exc.	C5AZ 8509J	#.5	1.95
	w/A.C.	C6AZ 8509A	#.5	3.75
	1966 6 Cyl. Standard	*C5AZ 8509K	#.7	2.55
		**C0DE 8509A	#.5	2.00
	w/A.C.	*C5DZ 8509A	#.7	3.75
		**C5DZ 8509A	#.5	3.75
	w/P.S.			
	Dealer	**C5AZ 8509K	#.5	2.55
	Factory	**C4DZ 8509A	#.5	2.90
	V8, exc.	*C6AZ 8509E	#.7	4.65
		**C5AZ 8509J	#.5	1.95
	w/A.C.	*C6AZ 8509F	#.7	4.65
		**C6AZ 8509A	#.5	3.75
		(#Incl. R&R Fan w/Radiator Rem. .2)		

Cont'd.